

50A-3PH

DVS3 mk2

- 3 ϕ current
- 0-50A per phase
- True RMS metering
- Multi-function timing system
- Auxiliary metering input
- Compact & portable
- 220V or 400V 3 ϕ supply options



- 3 ϕ voltage
- 0-133V ϕ -n
266V ϕ -n with optional VT box
- $\pm 180^\circ$ phase shift
- 40-999.9Hz
- 45VA/phase
- Multi-function timing system
- Compact & portable
- Single phase supply



Relay Test

T&R Test Equipment is renowned for its rugged, reliable and innovative relay test equipment solutions. The DVS3 mk2 voltage source and 50A-3PH current source provide the commissioning and maintenance engineer with a flexible 3 phase relay test system at a realistic price.

The units may either be used together to test directional and distance protection, or individually to test single and three phase voltage (DVS3) and current (50A-3PH) relays. The

DVS3 also excels in testing G59 embedded generation protection, including voltage, frequency, vector surge and df/dt (ROCOF) relays.

The DVS3 runs from a 230V single phase supply, and the 50A-3PH from a 400V 4 wire, 3 phase supply. An optional delta-star supply converter is available, allowing the DVS3 and 50A-3PH to use a 115V, 230V, 400V or 440V 3 phase 3 wire supply.

Applications

50A-3PH

- Over and under current relays
- Miniature circuit breakers
 - Earth fault relays
 - Auto-reclosers
 - IDMT relays

50A-3PH+DVS3 mk2

- Directional overcurrent relays
- Distance protection relays
 - Phase angle relays
 - Power transducers
 - Power relays

DVS3 mk2

- Under and over frequency relays
- Under and over voltage relays
 - df/dt & ROCOF relays
 - Synchronising relays
 - Vector surge relays

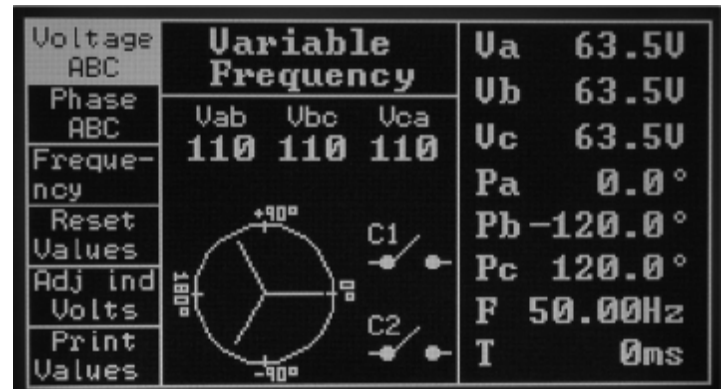

The displays on both the 50A-3PH and DVS3 mk2 are large, clear and easy to read. Both are back-lit liquid crystal displays, and show all operating parameters of the units at all times.



T&R Test Equipment Ltd



50A-3PH Applications

Overcurrent/IDMT relays

The 50A-3PH is ideally suited to testing single and three phase overcurrent relays. Testing is simplicity itself:

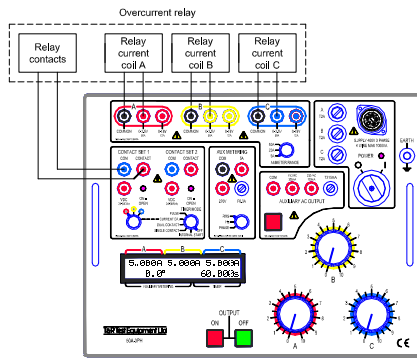

Set the timer mode to "off" and switch the output on.

Set the required currents for each phase, and switch the output off.

Set the timer mode switch to "Internal start", and press the "on" pushbutton.

The timer will reset, start and current injection commences.

When the relay contacts change state, the timer stops and the current is switched off. All three currents are held on the display from the moment the relay tripped, and displayed with the trip time.

Miniature Circuit Breakers and Trips

Testing devices with no auxiliary contacts is no problem. The 50A-3PH's current operated mode starts and stops the timer from the rise and fall of the output current.

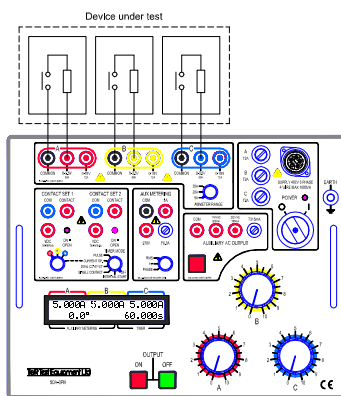

Set the timer mode to "off" and switch the output on.

Set the required currents for each phase, and switch the output off.

Select the "Current operated" timer mode, and press the "on" pushbutton.

The timer will reset, start and current injection commences.

When the breaker trips, the timer stops. All three currents are held on the display from the moment the relay tripped, and displayed with the trip time.

Auto-reclosing relays

The 50A-3PH's flexible timing system easily handles timing of auto-reclosing devices. Sensitivity of the contacts to changes of state rather than open or closed simplifies the setup for all timing functions, and this type of relay in particular.

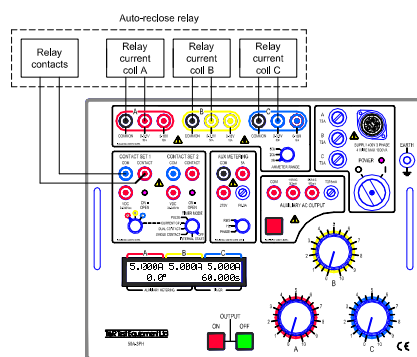

Set the timer mode to "off" and switch the output on.

Set the required currents for each phase, and switch the output off.

Set the timer mode switch to "Single contact", and press the "on" pushbutton.

The timer will reset, and current injection starts.

When the relay contacts change state for the first time, the timer starts and the current is switched off. All three currents are held on the display.

When the relay recloses, the timer stops and displays the reclose time.

50A-3PH

The two-contact timing system on the 50A-3PH is very flexible, and geared to the timing of current relays. Two sets of isolated contacts sensitive to changes of state are linked to an easy to understand mode control. The following modes are provided:

Internal start: The timer starts when the output is switched on, and stops when contact set 1 (CS1) changes state.

Single contact: The timer starts on the first change of CS1, and stops on the second change.

Dual contact: The timer starts on a change of state on CS1, and stops on a change of CS2.

Current operated: The timer starts when the output current exceeds 20% of the selected ammeter range, and stops when it falls below 20%.

Pulse mode: The output is switched on for 600ms.

In each case, the timer is reset and armed when the output is switched on.



Timing Systems

DVS3 mk2

The DVS3 mk2 timer is transparent in operation, triggered by any step change of output value. If the relay contacts are connected, you'll be able to time the relay without realising you have!

To generate a step change of frequency on the DVS3 output, just type a new value on the keypad. When you press enter, the frequency steps from the old value to the new value, and the timer resets and starts. A change of state on the contacts will then stop the timer.

The system is very flexible, and is triggered from step changes of voltage, phase and frequency. In each case, the timer is reset and started when a new value is typed in and the enter key pressed.

More complex timing tasks can be undertaken using the pre-fault, fault, post-fault mode.



Directional overcurrent relays

When used together, the DVS3 mk2 and 50A-3PH are able to test many types of complex protection requiring three voltage and three currents. Testing three phase directional overcurrent relays is well within the capabilities of this system. Phase A of the output current is used to provide a phase reference to the DVS in this configuration. Phase A of the DVS output voltage is then in phase with current A when 0° is shown on the DVS display. To test the relay, first select phase lock mode-external lock on the DVS and switch on the output.

Switch on the 50A-3PH output with the timer in the off position, and increase the current on each phase to the setting current of the relay (1A on a 1A relay). This sets the current reference for finding the restraint angle of the relay. The restraint angle

of the relay may now be found by rotating the voltage vectors on the DVS. Mimics of the relay contacts are shown next to the phase on the display to make this easy. The graphical vector diagram makes finding the approximate restraint angle simple, and the text display gives an accurate result.

To time the relay, set the current to the desired level on the 50A-3PH, switch the output off, and select "internal start" timer mode. When the "on" pushbutton is pressed, the timer resets and starts and current injection commences.

When the relay contacts change state, the timer stops and the current is switched off. All three currents are held from the moment the relay tripped, and displayed with the trip time.

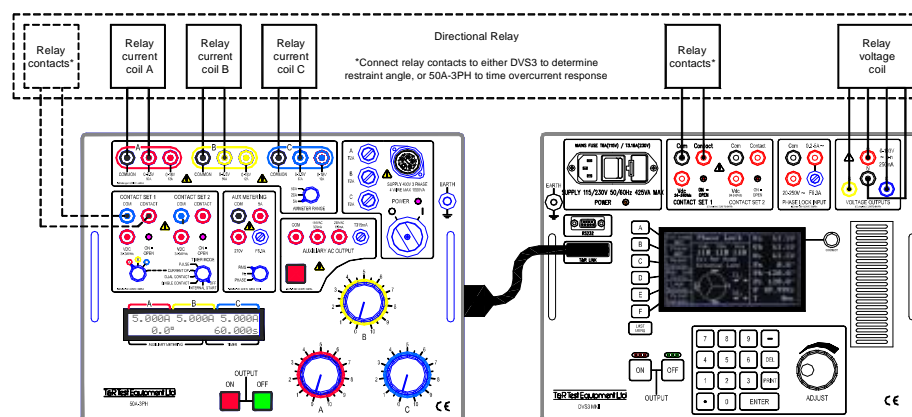

DVS3 mk2 Applications

Over voltage relays

Operating points and times of under and over voltage relays may be found with ease using a DVS3 mk2. This example uses a 63.5V relay.

Enter the relay operating voltage using the keypad (press 63.5 and ENTER to set 63.5V for phase A, B, and C together). Switch the output on.

Increase the output voltage using the "adjust" knob until the relay trips. Record the voltage—this is the operating point of the relay. Set the DVS3 mk2 back to 63.5 using the keypad.

Enter a voltage that will trip the relay using the keypad (e.g. 70V). When ENTER is pressed, the timer resets and starts, and the output voltage changes. When the relay operates, the timer stops.

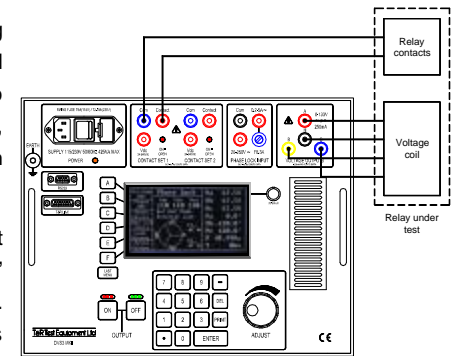

df/dt relays

Rate of Change of Frequency (ROCOF) or df/dt relays are frequently used in loss of mains protection in embedded generation schemes. The DVS3 makes light work of an otherwise difficult test.

The ROCOF mode on the DVS3 allows the output frequency to be swept between minimum and maximum values at a programmable rate. The frequency may be continuously swept, or single sweeps applied. When single sweeps of frequency are used, the timer automatically starts when the sweep starts, allowing the response of a df/dt relay to be timed.

To test a ROCOF relay, set the desired minimum and maximum frequencies, and gradually increase the rate of change until the relay trips. Greater accuracy may be achieved using the single sweep mode; many ROCOF relays do not have the same sensitivity to rising and falling changes of frequency.

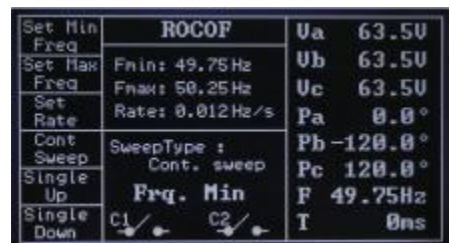

Vector surge relays

Vector surge (relays sensitive to changes of phase with time) may be easily tested with the DVS3. In variable frequency mode step phase changes may be generated at any frequency between 40 and 1000Hz.

To generate a phase step on all three phases, first enter phase adjustment mode by pressing "Phase ABC". start with phase A at 0°, and enter a new value (e.g. 6° by typing 6 ENTER). When enter is pressed, the output steps to 6°, creating a +6° phase step. Setting a phase angle of zero will then result in a phase step of -6°. In this way a series of increasing positive and negative phase steps can very easily be generated to find the operating point of a vector-surge relay.



50A-3PH Specification

Please refer to the 50A-3PH and DVS3 mk2 data sheets for full specifications

DVS3-mk2 Specification

The main output on the unit has two taps, allowing the selection of output voltages up to 18V and output currents up to 50A.

Range	Continuous	5 minutes	1 minute
3.5V	16A	32A	50A
18V	4A	8A	12A

The above intermittent on times must be followed by an off time of 15 minutes, and are based on an ambient temperature of 25°C.

Metering

The output is metered by a digital true RMS system with a memory ammeter - whenever the timer stops and the output is switched off, the current reading is held on the display.

Range	Resolution	Trip current	Accuracy
5.000A	0.001A	5.25A	±0.6%rdg+5d
20.00A	0.01A	21A	±0.6%rdg+5d
50.00A	0.01A	52.5A	±0.6%rdg+5d

A current trip is automatically set to 105% of full scale of the current metering range to protect the device under test.

Auxiliary Metering Inputs

An auxiliary metering input is provided which is able to measure RMS voltage or current. In addition the frequency of the external input may be measured, and the phase measured between any of the phase outputs and the auxiliary metering input. The current input is fuse protected.

	Range	Resolution	Accuracy
Volts ac	270.0V	0.1V	±0.7%rdg+5d
Amps ac	5.000A	1mA	±0.7%rdg+5d
Phase	±180°	0.1°	±3°
Frequency	20-1000Hz	0.1Hz	±0.2%rdg+1d

Auxiliary Output

A single phase isolated auxiliary output of 110V 300mA or 230V 110mA (33VA) is provided on the 50A-3PH. An optional external unit is available to convert this output to variable 0-110/220Vac or 0-150/300Vdc.

Timing System

Range	0-999.999s	Resolution	1ms
Accuracy	0.01%rdg+2d (+4d current operated mode)		

Each contact circuit auto-selects for normally open or normally closed contacts. A DC voltage may also be used to trigger the timer. The output is automatically switched off at the end of the test.

Mode	Timer Start	Timer Stop
Internal start	Press 'ON'	Contact 1
Single contact	Contact 1	Contact 1
Dual contact	Contact 1	Contact 2
Current operated*	Current > 10% of range	Current < 10% of range
Pulse mode	Current injected for 600ms	

*Current operated mode operates on one output phase (selectable).

Supply Requirements

The unit is available for operation from either a 400V 4 wire supply or 220V 3 wire supply. The optional delta-star supply transformer allows the 400V unit to operate from 115V, 230V, 400V and 440V 3 wire supplies.

Supply : 400V*±10%+14% or 220V*±6%+14% 50/60Hz 3ph 1000VA

*Specify at time of ordering

Dimensions

380mm x 314mm x 221mm

Weight

21kg

	Range	Resolution	Accuracy
Voltage	0-133VAC p-n	0.1V p-n	±0.3%rdg+3d
Var. frequency	40.00-99.99Hz	0.01Hz	±0.01%rdg+1d
	100.0-999.9Hz	0.1Hz	±0.01%rdg+1d
PL frequency	45.00-65.00Hz	0.01Hz	±0.01%rdg+1d
Phase rotation	±180°	0.1°	±0.3° p-p ±3.0° ref to o/p
Timer	0-999.999s	1ms	±0.01%rdg+2d
O/P rating	200mA at 0.1V	335mA at 133V	5 min on/15 off

Timing System

The timing system on the DVS3 mk2 is flexible and transparent in operation. Step changes of any quantity may be generated by typing in value using the keypad. Entering a value in this way automatically resets and starts the timer when the change is applied. The timer then stops on a change of state of either contact input. More complex timing functions are handled by the PF-F-PF mode.

Variable Frequency Mode

This mode allows full control of frequency, voltage and phase. The voltage and phase may be controlled individually for each phase or for all three phases together. All parameters are continuously variable using the adjust control, and step changes of any value may be generated by typing the required value on the keypad.

Phase Lock Mode

The frequency and phase of the output are controlled by an external reference in phase lock mode. The reference may be the mains supply to the DVS3 mk2, an external voltage, or an external current. This mode allows testing of directional and distance protection in conjunction with an external current source. The unit may be automatically phase locked to the 50A-3ph through the T&R Link lead.

Phase lock range	45-65Hz
External reference	Voltage 20-250Vac, Current 0.2-5A AC

df/dt and ROCOF (Rate Of Change Of Frequency)

The DVS3 mk2 is able to generate a swept frequency output with accurate rates of change of frequency between preset frequencies. The rate of change may be continuously varied to find the relay setting or stepped to time the relay. The output may be set to either sweep continuously or generate single sweeps with timing.

Frequency range	45.00-65.00Hz
Default sweep range	49.75-50.25Hz (50Hz supply)
Rate of change range	0.010-3.000Hz/s

Pre-fault - Fault - Post-fault Mode

PF-F-PF mode allows extra flexibility in testing where complex events must be timed or several sets of values must be applied to a relay in turn. This mode allows three sets of values to be set in advance (pre-fault, fault, and post-fault values). The DVS3 mk2 may be set to switch from one state to the next on a change of contact or after a specific time. In addition, the timer may be set to start or stop on any one of the state changes of a change of contact state. This mode allows frequency, phase and voltage to be changed simultaneously if required.

Supply Requirements

115V±10%/230V±10% auto-selecting. 45-65Hz, 1ph, 425VA max

50A-3PH and DVS3 mk2

Contact O/C voltage	24V	Contact S/C current	20mA
Vdc input range	24-240Vdc		

Accessories

Both units are supplied with an output lead set in a carrying case, operating manual, spare fuses and mains lead

Protection and Safety

The DVS3 mk2 and 50A-3PH are CE marked and designed to meet the requirements of BS EN61010. An earth terminal is provided for connection to a local earth.

Temperature Range

Storage -20°C to 60°C Operating 0°C to 45°C

T&R Test Equipment Ltd, Keens Lane, Worplesdon, Guildford, Surrey, GU3 3LS, UK
Tel: +44 (0)1483 235757 Fax: +44 (0)1483 235759 email: sales@trtest.com

www.trtest.com